

Grain Artisanship & Value Chains

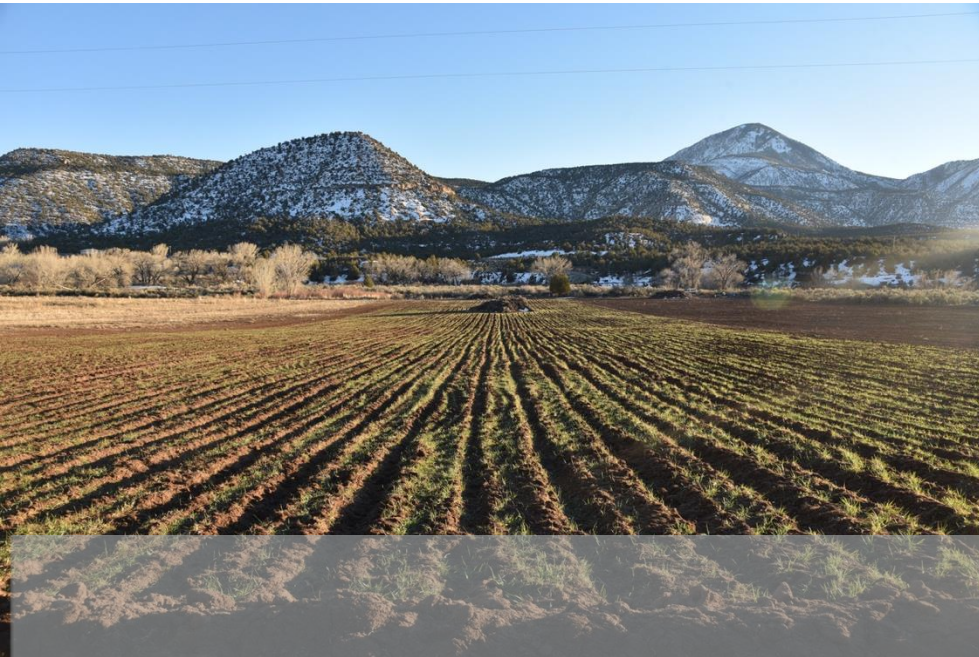

Dan Hobbs



Objectives: Discuss artisan grains in small & mid-scale farming systems, infrastructure & grain quality, grain value chains, and vertical integration

Our Value Proposition: Drought tolerant heritage and ancient grains along with select open pollinated modern varieties for flavor and health.

Grain in Diversified Farming Systems



Varietal Selection, Stock Seed & Planting



Spring
vs
Winter
*
Wheat
Rye
Barley
Oats
*
Millets & Sorghum
Corn
Amaranth & Quinoa
Buckwheat
*
Inter Planting
with Legumes



Trials

2020 trials included 14 varieties. 2021 trials a repeat of 2021 best selection and additional varieties selected from USDA GRIN.



Analyses show evidence of high nutrient content (especially iron/zinc and other minerals) from Organic field trials in Pueblo, Colorado .

**Harvesting
into
Buckhorn Bins
2500 lbs**





Pre-Cleanings

Safety Precautions

HACCP

Mycotoxin
Testing



Field to Storage

Seed Cleaning

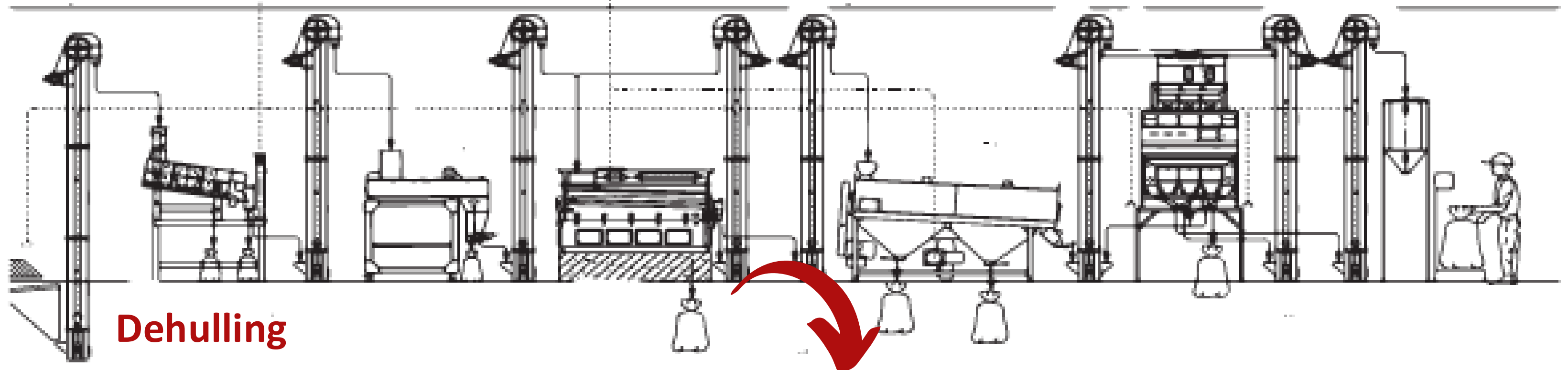
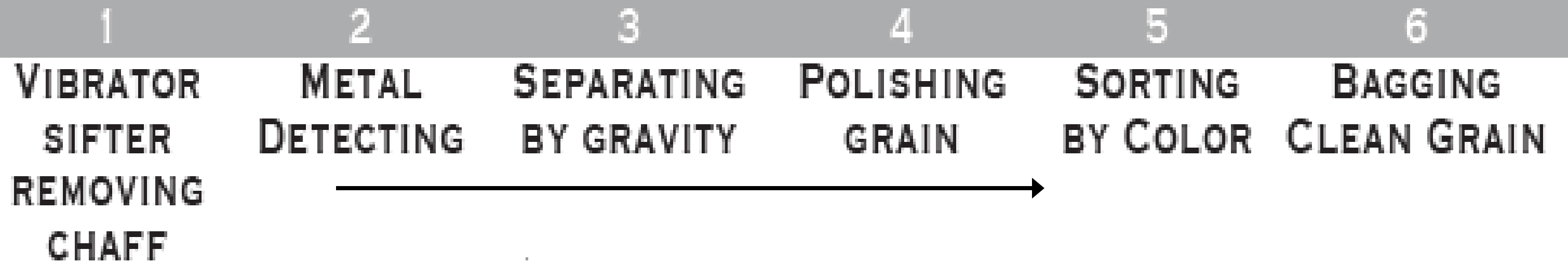

Regional Grain Value Chains

SOUTHWEST
GRAIN
COLLABORATIVE



Origins of alternative grain networks
are likely mills
often with support of nonprofit
organizations

Anson Mills, South Carolina
Hayden Flour Mills, Phoenix, AZ
Heartland Mills, KS
Mountain Mama Milling, CO



Farmer

Breeder
Scientist



Grain Handler
Miller
Malster



WILD LEAVEN BAKERY



Baker
Brewer
Distiller
Chef/Cook



D R Y LAND

Grain Chains

Beverages Driving the Market

Grain Chains: Opportunities & Risks

1. Establishing Local & Regional Grain Economies
2. Farm & Food Diversification
3. Planetary & Consumer Health
4. Community Building & Cultural Resilience

1. Geographic Dispersion

2. Lack of Infrastructure

3. Lack of Developed Systems, including safety

4. Lack of Markets & Early Competition

5. Lack of Consumer Involvement

6. Lack of collaboration/Cooperation

Equipment Sharing & Cooperative Agreements



**Rocky Mountain
Farmers Union**

Vertical Integration of Small Grain Businesses



Colorado Malting Company, San Luis Valley, CO
Black Cat, Boulder, CO

Vertical Integration

PUEBLO SEED  FOOD CO.



IMPROVE YOUR EFFICIENCY



IMPROVE YOUR EFFICIENCY



IMPROVE YOUR EFFICIENCY

Sustainable Packaging

Licensing

1. FDA Facility Registration
2. Manufacturing
3. Wholesale
4. Retail/Grocery
5. Deli

According to FDA Food Rule

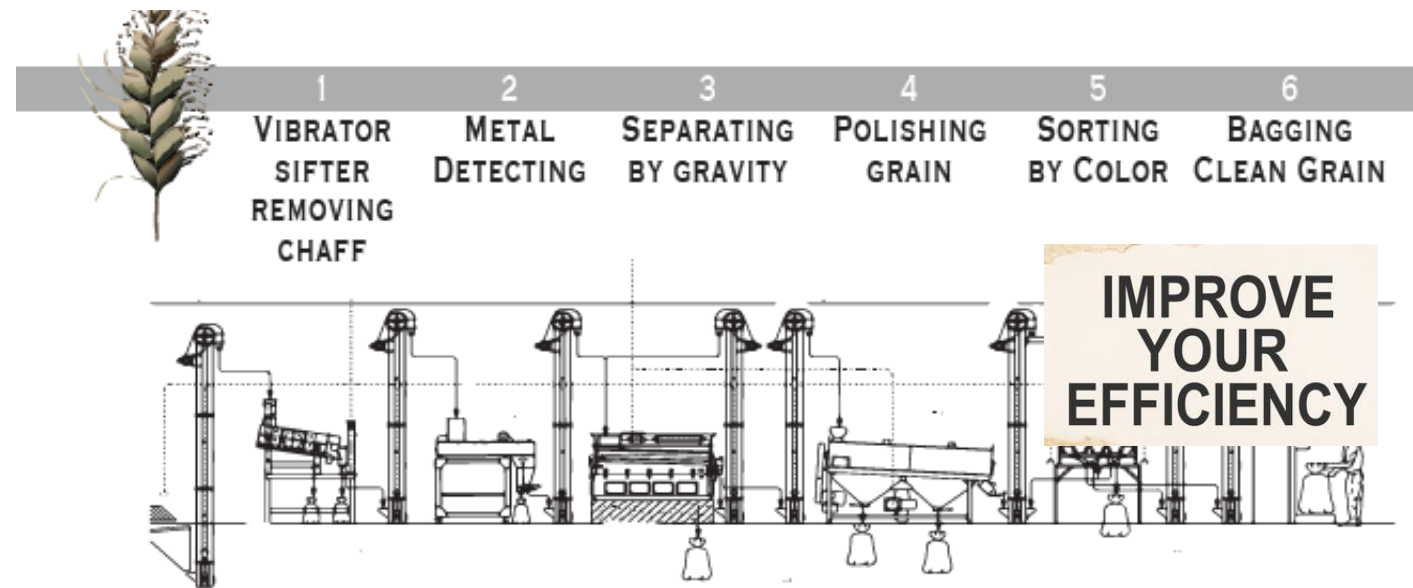

IMPROVE YOUR EFFICIENCY



IMPROVE YOUR EFFICIENCY



IMPROVE YOUR EFFICIENCY



Preventive Controls Pueblo Seed & Food Co.



Innovation
and
artisanship
in the
Pueblo
Seed &
Food
Bakehouse



COURSE STARTS FEBRUARY 3, 2025

Have ACCESS ALL YEAR

Includes all parts of UCCS Grain School with
Kick Off Orientation Session Feb 4, 2024 at 4.30 - 6pm MST



Sign up here:

